

Industrial printing

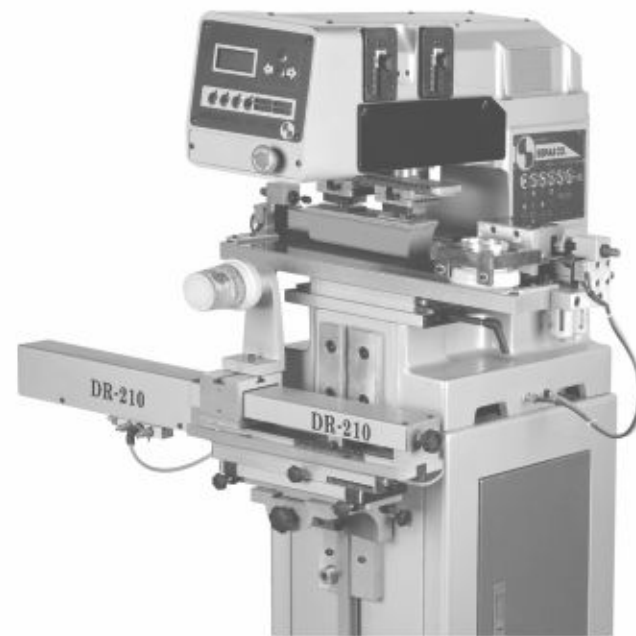
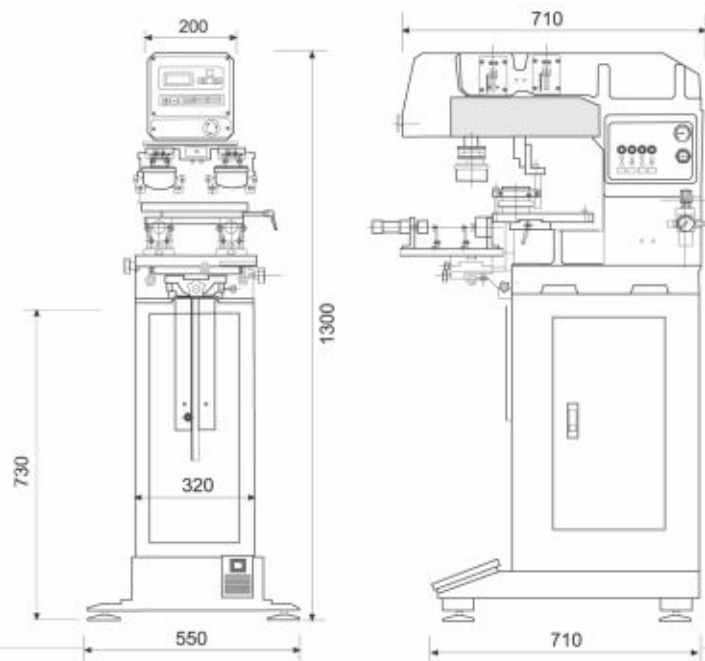

Access to Printing Solutions

Sepas F.Z.C

No 18, Block D, Ajman Free Zone P.O.Box: 21009, Ajman, UAE

Tel: +971 (0)6 7447852 Fax: +971 (0)6 7447853 Email: uae@sepas.com www.sepas.com

Our famous standard PP series pad printer is available for single colour up to 4 colour applications. Built to last with its rigid aluminium casting frame, PP-135 it can easily be combined with automation accessories for more capabilities. PP-135 pad printing machines represent the culmination of many years of customer input & continuous innovation suitable for various applications.

Technical Specifications	1 Colour	2 Colour
Plate Size (ink tray)	100 x 100,200,300 mm	100 x 300 mm
Max. Print area (ink tray)	40 x 350 mm	70 x 80 mm
Max. Print Area (CMIC)	Ø 70 mm	Ø 70 mm
Max Product size	200 x 300 mm	150 x 200 mm
Max. Speed	1500 Cycles/Hr	1200 Cycles/Hr
Max. Pad Pressure	710 N 6-8 BARS	1130 N 6-8 BARS
Power	220V 50/60 Hz 50W	220V 50/60Hz 50W
Air Consumption	80 Liter/min. (approx)	90 Liter/min. (approx)
Size (LxWxH)	W:710 H:550 L:1300	710 x 550 x 1300mm
Weight	100 Kg (approx)	120 Kg (approx)

## Pad Printing Machine

### Optional Accessories

- Automatic Feeder
- Additional open tray 100 x 100 x 200 x 300mm

### Features

- Single or two colour user-friendly automatic pad printer
- Flat and Round printing
- Pneumatic power operation
- Continuous printing action with pause/resume
- Multi language display
- Microprocessor, membrane switch control panel
- Automatic error finder
- Emergency interrupt
- Close system (CMIC) and open tray
- Thin plate, polymer cliché and steel plate
- Ink mixing mode
- Single-cycle mode
- Independent ink and print stroke settings
- Change ink cup or open tray in seconds
- Programmable for various requirements
- Single pickup / double print option
- Double pickup / single print option
- Independently adjustable print downstroke in two-colour mode
- Pad down and hold feature (print stroke only)
- Light & Rigid aluminum casting machine frame

